

# 3.7 Meter ESA

Like all CPI Antenna Systems Division earth station antennas, the 3.7 Meter Earth Station Antenna provides high gain and exceptional pattern characteristics.

This antenna system is designed to address the stringent requirements of both the television broadcast industry and telecommunications network operators who demand unsurpassed flexibility and electrical performance in high-quality, cost-effective, and reliable packages.

The electrical performance and exceptional versatility provides the ability to configure the antenna with your choice of linearly- or circularly- polarized 2- or 4- port combining networks. That versatility is provided at the time of initial purchase, as well as in the future, as your satellite communication requirements evolve.

This antenna system is used worldwide in broadcast applications and high density data, voice and communications networks. The CPI Antenna Systems Division 3.7 meter earth station antenna features a computer-optimized dual reflector Gregorian optics system and close-tolerance manufacturing techniques.

This combination provides extremely accurate surface contour resulting in exceptionally high gain and closely controlled pattern characteristics. CPI Antenna Systems Division earth station antennas provide maximum durability with minimal maintenance.



## Features

- Self-aligning main reflector
- 3 year warranty on all structural components
- Eutelsat Type Approval, 2-Port Ku-band EA-A002
- Asiasat Approval, Type 2
- Apstar Approval
- INTELSAT® Approval, E-2 at Ku-band: A12A00, 2-Port; IA12B00, 4-Port
- U.S. FCC Regulation 25.209 at Ku-band
- Russian Homologation Certificate OC/1-AO-136
- C, X, Ku, K Band Capabilities

# 3.7 Meter ESA

EARTH STATION ANTENNA

## Design Standards

Reflector	Aluminum painted with highly diffusive white paint
Ground Mount	Hot-dipped galvanized steel, per ASTM-A123 for structural steel.
Hardware	Sizes ≤ 3/8 in (9.5mm), stainless steel, passivated per MIL-F-14072-E300 Sizes ≥ 3/8 in (9.5mm), hot-dipped galvanized stainless steel, passivated per ASTM-A123

## Environmental Performances

Operating Temperature	-40° to 52°C (-40° to 125°F)
Seismic (Earthquake)	1 G Vertical and Horizontal acceleration. Equivalent to a Richter Magnitude 8.3, and Grade 11 on the modified Mercalli Scale
Operational Winds	45 mph (72 km/h) Gusts to 65 mph (105 km/h)
Survival Winds	125 mph (200 km/h) in any position of operation
Rain	4 in (102 mm) per hour
Solar Radiation	360 BTU/hr/ft <sup>2</sup> (1135 Watts/m <sup>2</sup> )
Relative Humidity	100%
Shock and Vibration	As encountered by commercial Air, Rail and Truck shipment.
Atmospheric Conditions	As encountered by Moderately Corrosive Coastal and Industrial Areas.

## Mechanical Performances

The 3.7m Antenna mechanical general specifications and performances are listed in below table. Additional information, dimensions and layout may be provided by CPI Antenna Systems Division on a case-by-case basis.

Optics Type	Dual Reflector Gregorian
Reflector Material	Precision-Formed Aluminum
Reflector Segments	2
Mount Type	EI over Az, Pedestal Mount

### Antenna Pointing Range, Coarse/(Continuous)

Elevation:	0-90° (90°)
Azimuth:	180° (120°)
Polarization	180° (180°)

### Hub/Enclosure Dimensions

Diameter	1.22 m (48 in)
Depth	0.61 m (24 in) optional 0.83m (32.5 in)

## Shipping Information

### Packing Options

Standard Commercial Domestic Pack	Included
Ocean Export Pack - For non-containerized, packed for seal against salt water spray	OCEANSHP-SML
Air Export Pack - For freighter aircraft shipments. Lower deck AirPack requires specialized bids	AIR EXPORT PACK-SML
Container Packaging	CNTPCK-SML

### Required Shipping Container

Standard 20 ft land/sea container	Quantity 1
-----------------------------------	------------

Shipping container information is given for basic configuration and may vary depending on the selected options, please contact CPI Antenna Systems Division for specific container loading plan.

# 3.7 Meter ESA

## Dimensional Drawings Non Motorizable Mount

EARTH STATION ANTENNA

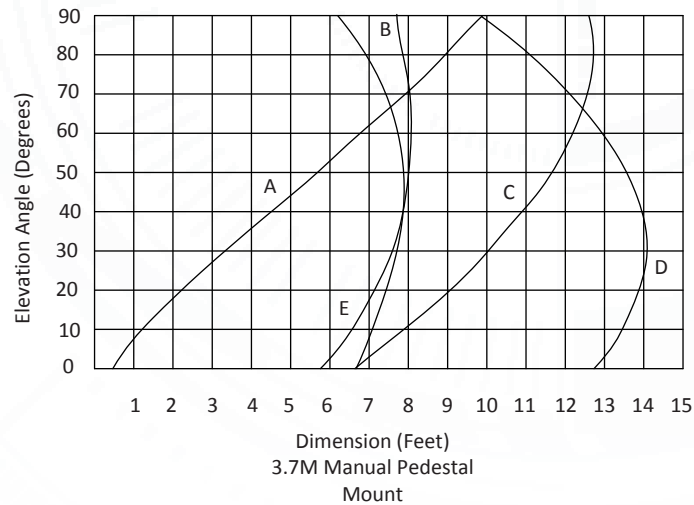
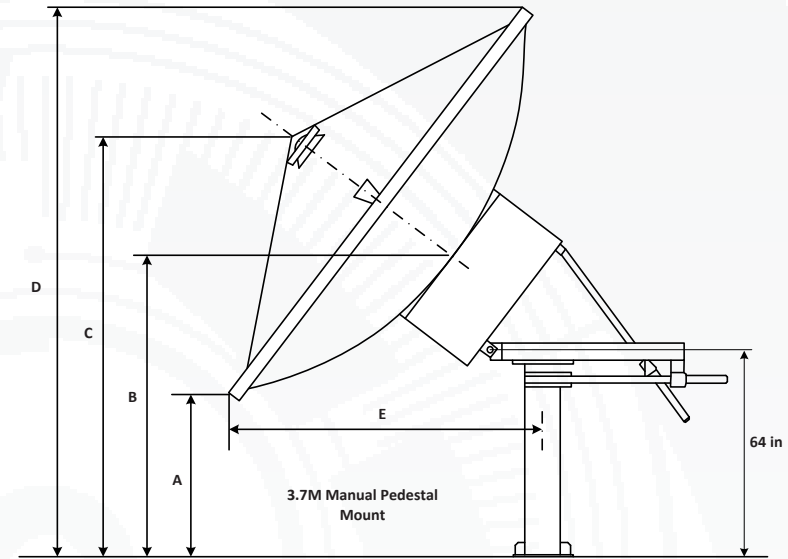
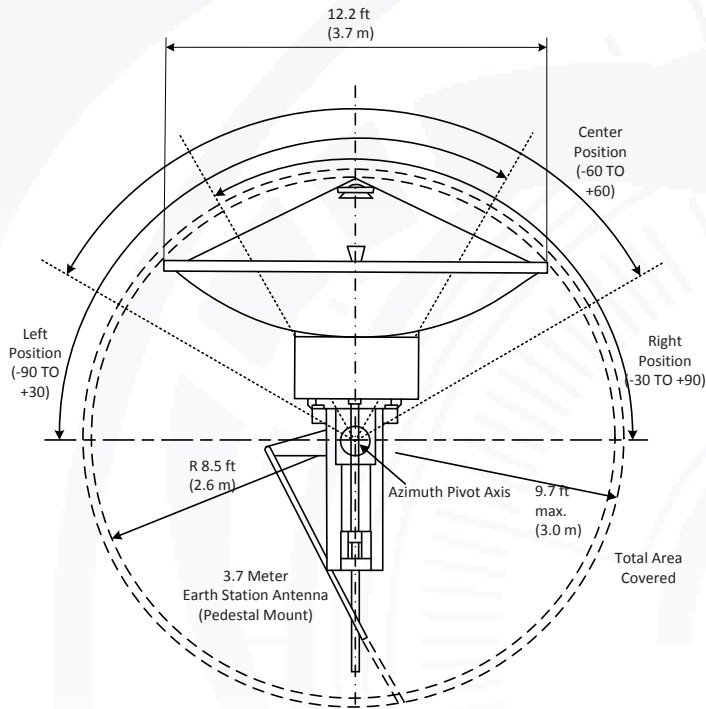

# 3.7 Meter ESA

## Dimensional Drawings Motorizable Mount

EARTH STATION ANTENNA

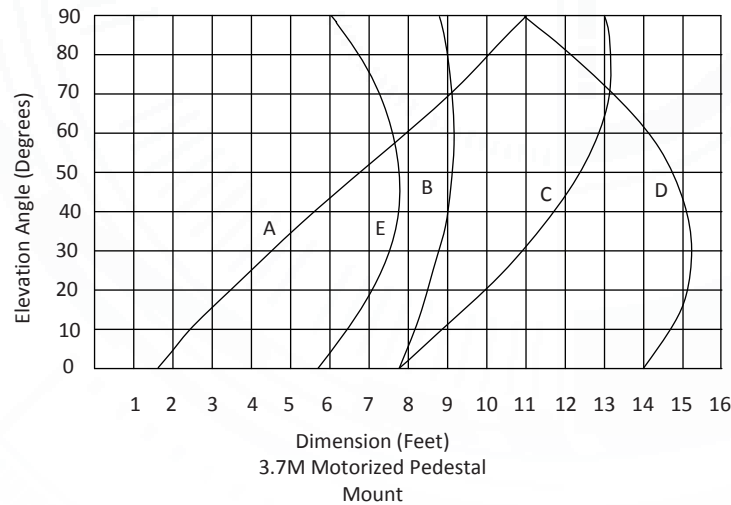
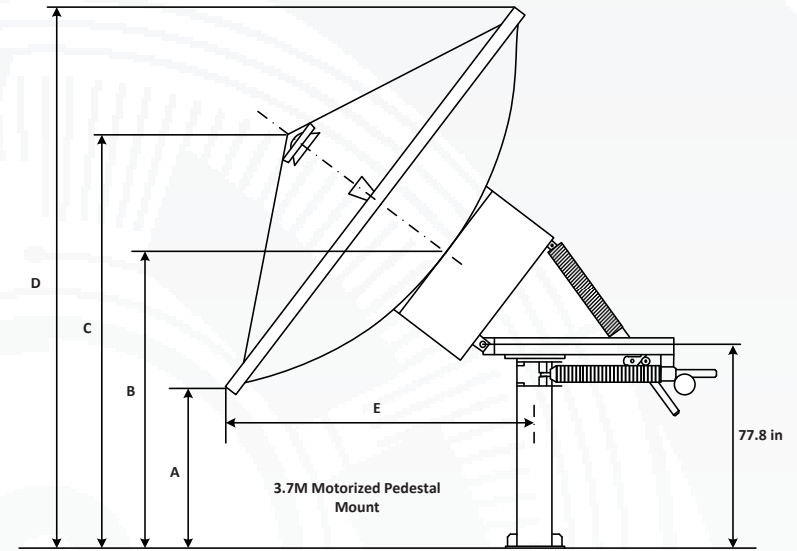
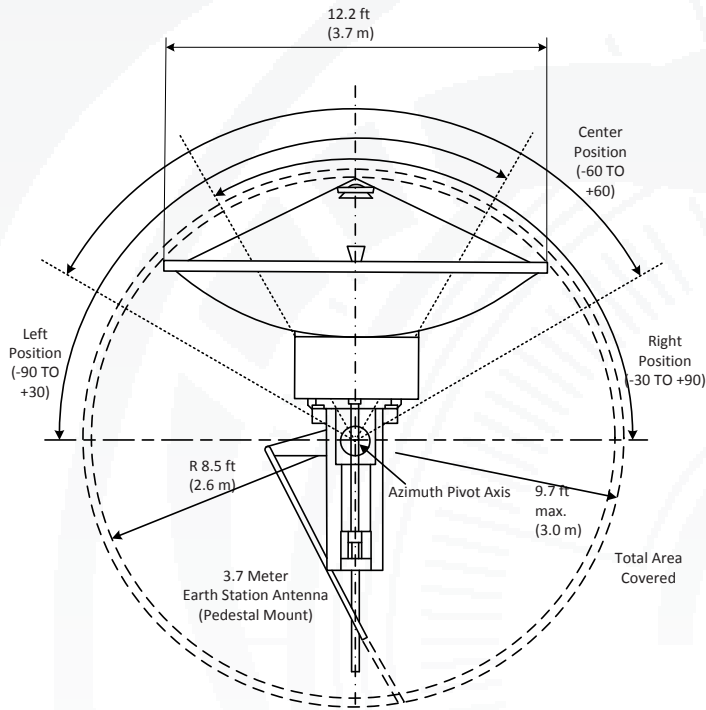

# 3.7 Meter ESA

## Foundation, Typical Slab

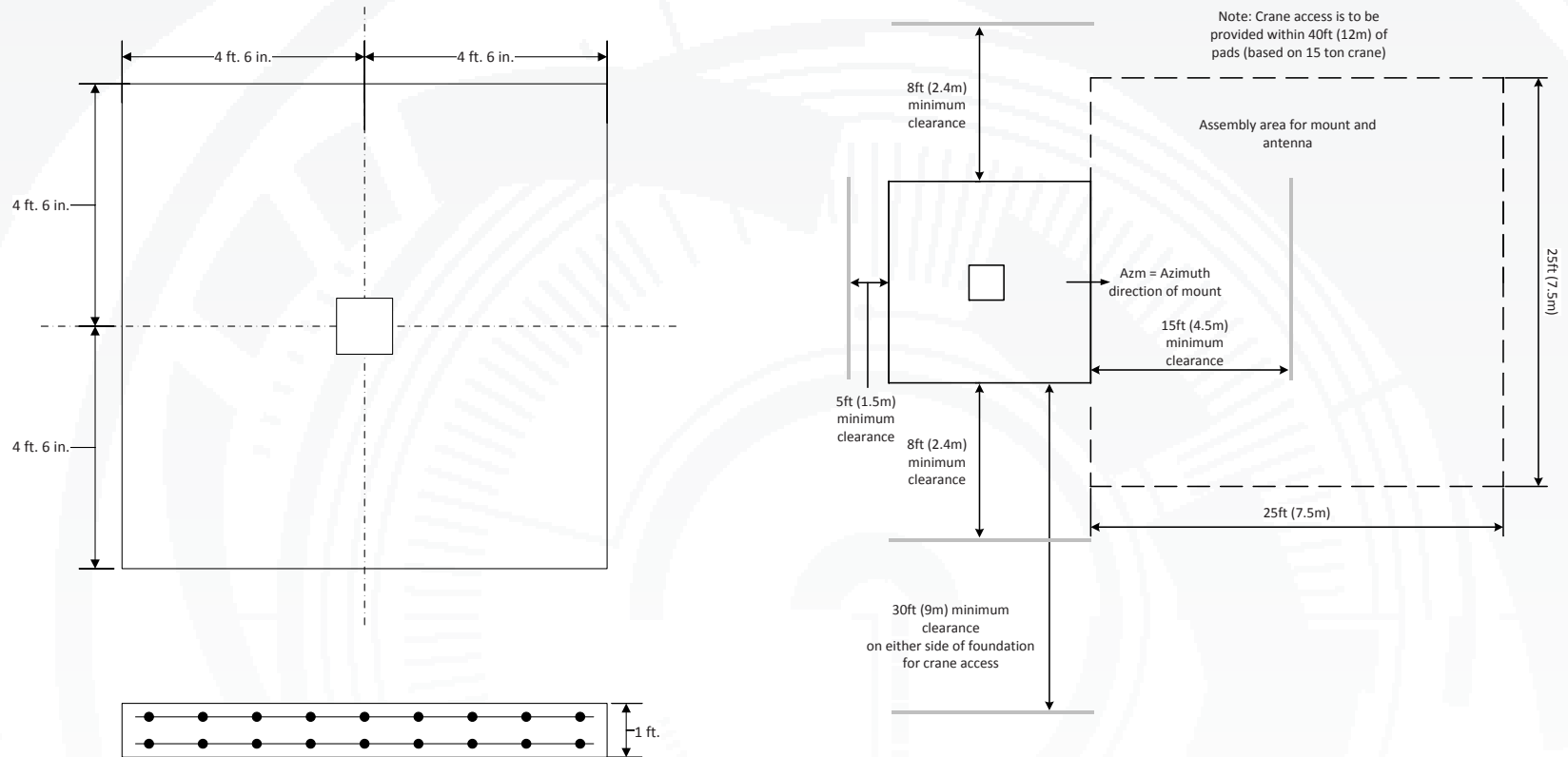

Foundation information are provided in bulletin 37835A, please contact CPI Antenna Systems Division.

Soil Bearing Capacity,	2000 lb/ft <sup>2</sup> (9770 kg/m <sup>2</sup> )
Reinforcing Steel,	194 Lbs (88 Kilograms)
Concrete Compressive Strength,	3000 psi (211 kg/cm <sup>2</sup> )
Foundation Size:	(for specific standard soil and typical design)
Length	9 ft (2.74 m)
Width	9 ft (2.74 m)
Depth	1 ft (0.305 m)
Concrete Volume	3 yd <sup>3</sup> (2.3 m <sup>3</sup> )

NOTE: Other typical foundation designs are available. Soil borings and foundation analysis should be performed by a qualified civil engineer.

# 3.7 Meter ESA

EARTH STATION ANTENNA

## Motor Drive Speed Summary

	Variable	
Azimuth	0.5°/s	0.05°/s
Elevation	0.5°/s	0.05°/s
Polarization	1°/s	

## Motorization

One motorization system is available for this antenna: the NGC tracking system that can support Steptrack, Smartrack and Ephemeris orbital tracking.

### Motor Kit

Azimuth/Elevation Motor Kit	NGC-MK4
-----------------------------	---------

### Polarization Drive Kit (DC Step Motors)

Standard Temperature (> -20°C)	NGC-PK5DRA
--------------------------------	------------

### Outdoor Unit Controller (Tracking)

Power 200 - 230 VAC, 3 Phase 50/60 Hz	NGC-ODU-208-3
Power 380 - 460 VAC, 3 Phase 50/60 Hz	NGC-ODU-380-3

Antenna controller, motorization and options are detailed in specific bulletins, please contact CPI Antenna Systems Division..

## Antenna Configurations

### X, Ku, K Band Earth Station Antennas

Manual Pedestal Mount.	ES37PK-1
Motorizable Mount without Az/EI Jackscrews.	ES37MPK-1
Motorizable Mount with Az/EI Jackscrews.	ES37MPJK-1

### C Band Earth Station Antennas

Manual Pedestal Mount.	ES37PK-EC-1
Motorizable Mount without Az/EI Jackscrews.	ES37MPK-EC-1
Motorizable Mount with Az/EI Jackscrews.	ES37MPJK-EC-1

## Motorization and NGC Options

Indoor	
NGC-IDU	NGC Rack Mounted Antenna Controller W/LCD Touch Panel
NGC-001	NGC-IDU Analog Telephone Modem
NGC-002	NGC-IDU Spectrum Analyzer Card, Analog
NGC-003	NGC-IDU DVB Receiver Card
NGC-004-02	NGC IDU, L-Band Internal Beacon Receiver
NGC-006	NGC-IDU Emergency Stop Button
NGC-007	NGC-IDU 10 Mhz Reference Source
NGC-008	NGC-IDU Redundant Power Supply
NGC-009	NGC-IDU Rack Slides
NGC-101	NGC-IDU Step Tracking Software
NGC-102	NGC-IDU Smartrack Software
NGC-103	NGC-IDU Predictive Track Software
NGC-104	NGC-IDU Full Tracking Capability Software
NGC-106	NGC-IDU Remote Access Software Package
NGC-107	NGC-IDU Spectrum Analyzer Enhanced User Interface
NGC-108	Receive Pattern Test Tool
NGC-109	Redundancy Control Software
NGC-111	Sand/Dust Deviator Feature
NGC-119	NGC High Availability System Redundancy Software

Outdoor	
NGC-201	NGC ODU Low Temperature Kit (-40 C)
NGC-202	NGC ODU High Temperature Kit (+60 C)
NGC-205	NGC ODU AC Polarization Drive Interface
NGC-206	NGC Exterior Emergency Stop Button
NGC-207	Pre Movement Alert Warning Light And Annunciator
NGC-211	Dual Path NGC Redundancy
NGC-AESC	Environmental System Controller



# 3.7 Meter ESA

## Feed Matrix

C- BAND FEED SYSTEMS	PORT	CP	LP	RX 3.625 - 4.2 GHz	TX 5.850 - 6.425 GHz
2CPC-37-109	2	X	X	X	X
2CPCR-37-109	2	X		X	

X- BAND FEED SYSTEMS	PORT	CP	RX 7.25 - 7.75 GHz	TX 7.9 - 8.4 GHz
2CPX-37	2	X	X	X

Ku- BAND FEED SYSTEMS	PORT	LP	RX 10.95-12.75 GHz	RX 10.95-12.25 GHz	RX 10.7 - 12.75 GHz	RX 10.7 - 13.25 GHz	RX 10.7 - 11.7 GHz	TX 12.75-13.25 GHz	TX 14.0 - 14.5 GHz	TX 13.75-14.8 GHz
2LPK-37-W	2	X	X						X	
2LPKR-37-W	2	X	X							
2LPKUNV-37	2	X				X				X
4LPK-37-W	4	X		X					X	
4LPKUNV-37-1	4	X			X					X
4LPKUNV-37-2	4	X					X	X		X

K- BAND FEED SYSTEMS	PORT	LP	CP	RX 10.7 - 12.75 GHz	TX 17.3 - 18.4 GHz
2LPKK-37	2	X		X	X
4LPKK-37	4	X		X	X

# 3.7 Meter ESA

## Antenna Options and Spares

EARTH STATION ANTENNA

Anchor Bolt and Template Kits Option	
203314	Anchor Bolt Kit for 3.7 Meter Earth Station

Azimuth and Elevation Cross Axis Waveguide Options	
1XAK-5	Ku-Band Cross Axis Waveguide Kit, 2-Port.
1XAKK-5	K-Band Cross Axis Waveguide Kit, 2-Port.
1XAX-37	X-Band Cross Axis Waveguide Kit, 2-Port.
1XPK-37	Ku-Band Polarization Waveguide Kit, 2-Port.
1XPKK-37	K-Band Polarization Waveguide Kit, 2-Port.
1XPX-37	X-Band Polarization Waveguide Kit, 2-Port.
2XAK-5	Ku-Band Cross Axis Waveguide Kit, 4-Port.
2XAKK-5	K-Band Cross Axis Waveguide Kit, 4-Port.
2XPK-37	Ku-Band Polarization Waveguide Kit, 4-Port.
2XPKK-37	K-Band Polarization Waveguide Kit, 4-Port.
2XPX-37	X-Band Polarization Waveguide Kit, 4-Port.

Heating Options	
FH4A	C-Band Feed Heater Kit
FHXA	X-Band Feed Heater
FH5A	Ku and K-Band Feed Heater
WEC37R-208-100	Electric Hot Air De-Ice System, 208 VAC, 3 Phase
WEC37R-380-100	Electric Hot Air De-Ice System, 380 VAC, 3 Phase

Upgrade Options	
37CUPGK	Kit to Convert from C-Band to Ku-Band
37CUPGX	Kit to Convert From C-Band to X-Band
37KUPGC	Kit to Convert From Ku-Band to C-Band
37KUPGX	Kit to Convert From Ku-Band to X-Band

Hub Equipment Options	
EMRGYLT-115	Emergency Hub Light Kit, 115 VAC
EMRGYLT-230	Emergency Hub Light Kit, 230 VAC
FV5-115	Fan and Vent Kit, 115 VAC
FV5-220	Fan and Vent Kit, 230 VAC
FV5HV-115	High Volume Fan and Vent Kit, 115 VAC
FV5HV-230	High Volume Fan and Vent Kit, 230 VAC
FV5HV-48	High Volume Fan and Vent Kit, 48VDC
HUBHTR-230	Antenna Hub Heater, 230 VAC
HUBLCNTR-115/240	Hub Power Center, 115/240 VAC
HUBLCNTR-230	Hub Power Center, 230 VAC
HUBLT-115	Hub Light Kit, 115 VAC
HUBLT-230	Hub Light Kit, 230 VAC

Safety Options	
ANTGND-5	Foundation Installed Grounding Kit
LRK5	Lightning Rod Kit
OBWRNLT-UNV	Obstruction Warning Light Kit

Other Options	
207885	Hand Crank Adjustment Kit
209906	Lubrication and Maintenance Kit
221196	Elevation Handwheel Kit (2 required)
BRNG-374676-X	Guard, Feed Window X-band
BRNG-3746-C	Guard, Feed Window C-band
BRNG-37-K	Guard, Feed Window K-band
BRNG-37-KU	Guard, Feed Window Ku-band
FTST	Feed System Testing
TK-MAN-SML	Tool Kit, Small Manual Antennas
TK-MOT-SML	Tool Kit, Small Motorized Antennas

Environmental Systems Options	
PDKU-37-208	Precipitation Deviator Ku-band 208 VAC, 3 Phase
PDKU-37-380	Precipitation Deviator Ku-band 380 VAC, 3 Phase

CPI Antenna Systems Division  
 1120 Jupiter Road, Suite 102  
 Plano Texas 75074  
 USA  
 Phone: +1-214-291-7654  
 Fax: +1-214-291-7655  
 www.cpii.com/ascsignal  
 ASC.Sales@cpii.com

