

9.1 Meter ESA

Like all CPI Antenna Systems Division the 9.1 Meter Earth Station Antenna gives you high-performance in C-, X-, Ku- or K-band geostationary satellite applications. This earth station antenna provides superior performance through the use of precision stretch-formed reflector panels and a dual-shaped Cassegrain feed. Corrugated conical feed horns ensure excellent antenna gain and sidelobe performance. Forty-eight high-strength aluminum panels are durable enough to withstand rough handling and a range of environmental conditions. Antenna panels mount to radial trusses attached to a central hub. The hub also provides a protective enclosure for sensitive electronics. The high-strength structural steel mount employs an elevation over azimuth geometry for easy pointing to any satellite within the visible orbital arc. The mount's stiff, rugged construction provides pointing accuracy for continuous operation, even under adverse wind conditions.

This antenna includes a TORQUETUBE™ mount with continuous 120° of motorized azimuth coverage in three overlapping sectors.



Features

- Compliant with FCC, ASIASAT, INTELSAT, EUTELSAT, ITU and more
- Meets INTELSAT Standard F-3 requirements
- High-efficiency shaped Cassegrain optics
- Use with C-, X-, Ku or K-band systems (custom frequency options—consult factory)
- Minimal satellite repointing time with highspeed motorized option
- Large electronics space in hub
- Precision high-strength structural steel TORQUETUBE™ mount
- 180° continuous azimuth coverage option
- Full line of feed, reflector, and mount options available including TT&C pointing upgrade
- CE compliant

9.1 Meter ESA

EARTH STATION ANTENNA

Design Standards

Reflector	Aluminum painted with highly diffusive white paint
Ground Mount	Hot-dipped galvanized steel, per ASTM-A123 for structural steel.
Hardware	Sizes ≤ 3/8 in (9.5mm), stainless steel, passivated per MIL-F-14072-E300 Sizes ≥ 3/8 in (9.5mm), hot-dipped galvanized stainless steel, passivated per ASTM-A123

Environmental Performances

Operating Temperature	-40° to 65°C (-40° to 150°F)
Seismic (Earthquake)	1 G Vertical and Horizontal acceleration. Equivalent to a Richter Magnitude 8.3, and Grade 11 on the modified Mercalli Scale
Operational Winds	145 km/h; 90 mph Drive-to-stow
Survival Winds	161 km/h any position, 100 mph any position; 201 km/h stowed, 125 mph stowed;
Rain	4 in (102 mm) per hour
Solar Radiation	360 BTU/hr/ft ² (1135 Watts/m ²)
Relative Humidity	100%
Shock and Vibration	As encountered by commercial Air, Rail and Truck shipment.
Atmospheric Conditions	As encountered by Moderately Corrosive Coastal and Industrial Areas.

Mechanical Performances

The 9.1m Antenna mechanical general specifications and performances are listed in below table. Additional information, dimensions and layout may be provided by CPI Antenna Systems Division on a case-by-case basis.

Optics Type	Dual reflector, shaped axi-symmetric
Reflector Material	Precision-Formed Aluminum
Reflector Segments	48
Mount Type	EI over Az

Antenna Pointing Range Coarse/(Continuous)

Elevation:	0-90° (90°)
Azimuth:	160° in 3 overlapping 120° sectors Optional 180° continuous
Polarization	180° (180°)

Hub/Enclosure Dimensions

Diameter	
Depth	

Shipping Information

Packing Options

Standard Commercial Domestic Pack	Included
Ocean Export Pack - For non-containerized, packed for seal against salt water spray	OCEANSHP-LG
Air Export Pack - For freighter aircraft shipments. Lower deck AirPack requires specialized bids	AIR EXPORT PACK-LG
Container Packaging	CNTPCK-LG

Required Shipping Container

Standard 20 ft land/sea container	
Standard 40 ft land/sea container	

Shipping container information is given for basic configuration and may vary depending on the selected options, please contact CPI Antenna Systems Division for specific container loading plan.

9.1 Meter ESA

Dimensional Drawings

EARTH STATION ANTENNA

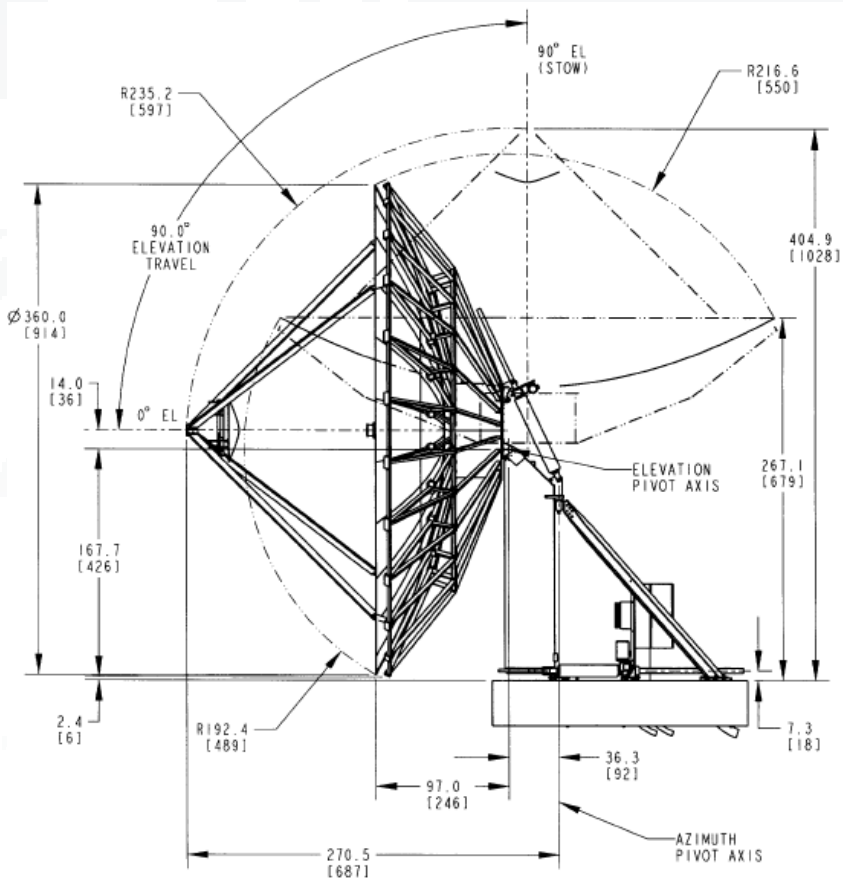
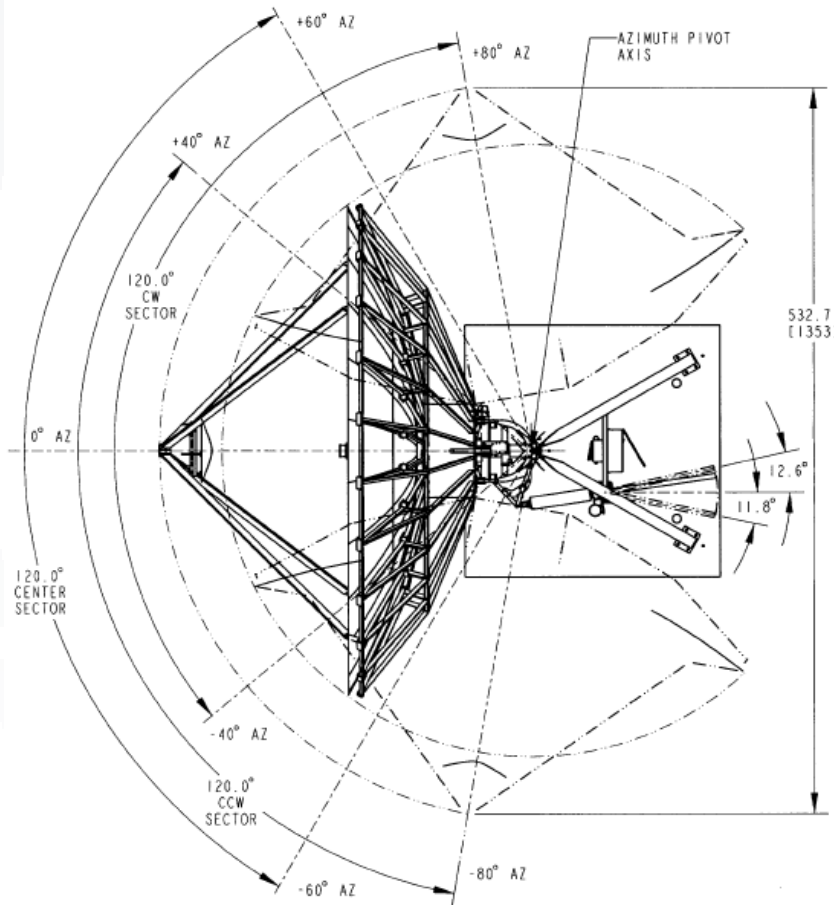

9.1 Meter ESA

Typical Foundation Design

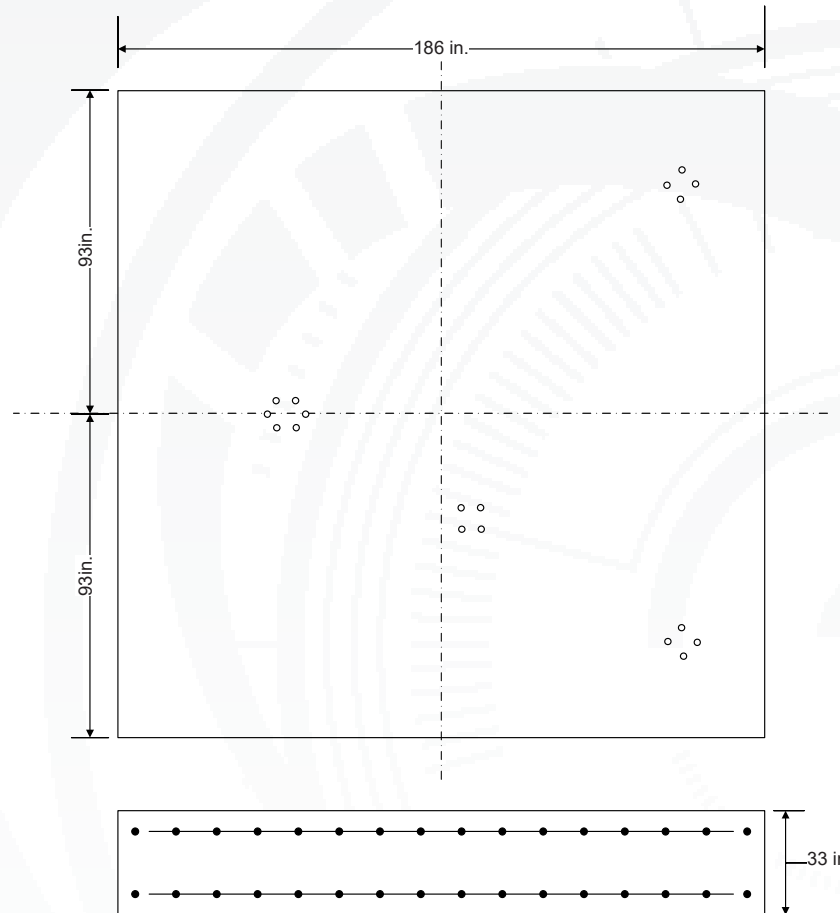

Soil Bearing Capacity,	not less than 2,000 lb. per sq. foot [96 kPa]
Reinforcing Steel,	
Concrete Compressive Strength,	3000 lb. per sq. inch [20685 kPa]
Foundation Size:	
Length	186 in (4.7 m)
Width	186 in (4.7 m)
Depth	33 in (0.84 m)
Concrete Volume	23.6 yd ³ (18.6 m ³)

NOTE: Other typical foundation designs are available. Soil borings and foundation analysis should be performed by a qualified civil engineer.

Foundation information are provided in bulletin xxxxxx, please contact CPI Antenna Systems Division.

9.1 Meter ESA

Motor Drive Speed Summary

	Variable	
Azimuth	0.05°/s	0.5°/s
Elevation	0.05°/s	0.5°/s
Polarization	1°/s	

Motorization

One motorization system is available for this antenna: the NGC tracking system that can support Steptrack, Smartrack and Ephemeris orbital tracking.

Motor Kit

Azimuth/Elevation Motor Kit	NGC-MK91
Azimuth/Elevation Motor Kit High Accuracy	NGC-MK91HA

Outdoor Unit Controller (Tracking)

Power 200 - 230 VAC, 3 Phase 50/60 Hz	NGC-ODU-208-5
Power 380 - 460 VAC, 3 Phase 50/60 Hz	NGC-ODU-380-5
Power 200 - 230 VAC, 3 Phase 50/60 Hz High Accuracy	NGC-ODU-208-5-HA
Power 380 - 460 VAC, 3 Phase 50/60 Hz High Accuracy	NGC-ODU-380-5-HA

Antenna controller, motorization and options are detailed in specific bulletins, please contact CPI Antenna Systems Division..

Antenna Configuration

Earth Station Antennas

120° Motorizable Mount with Az/EI Jackscrews.	ES91-1
180° Motorizable Mount with Az/EI Jackscrews.	ES91MPEX-1
Extreme Environment 120° Motorizable Mount with Az/EI Jackscrews.	ES91-EE-1
Extreme Environment 180° Motorizable Mount with Az/EI Jackscrews.	ES91MPEX-EE-1
TT&C 120° Motorizable Mount with Az/EI Jackscrews.	ES91-EE-1-TTC
TT&C 180° Motorizable Mount with Az/EI Jackscrews.	ES91MPEX-EE-1-TTC

Motorization and NGC Options

Indoor	
NGC-IDU	NGC Rack Mounted Antenna Controller W/LCD Touch Panel
NGC-001	NGC-IDU Analog Telephone Modem
NGC-002	NGC-IDU Spectrum Analyzer Card, Analog
NGC-002-EDR	NGC-IDU Spectrum Analyzer Card, Analog, Enhanced Dynamic Range
NGC-003	NGC-IDU DVB Receiver Card
NGC-004-02	NGC IDU, L-Band Internal Beacon Receiver
NGC-004-02-IDU	NGC 1RU, L-Band Beacon Receiver
NGC-006	NGC-IDU Emergency Stop Button
NGC-007	NGC-IDU 10 Mhz Reference Source
NGC-008	NGC-IDU Redundant Power Supply
NGC-009	NGC-IDU Rack Slides
NGC-101	NGC-IDU Step Tracking Software
NGC-102	NGC-IDU Smartrack Software
NGC-103	NGC-IDU Predictive Track Software
NGC-104	NGC-IDU Full Tracking Capability Software
NGC-106	NGC-IDU Remote Access Software Package
NGC-107	NGC-IDU Spectrum Analyzer Enhanced User Interface
NGC-108	Receive Pattern Test Tool
NGC-109	Redundancy Control Software
NGC-111	Sand/Dust Deviator Feature
NGC-119	NGC High Availability System Redundancy Software
Outdoor	
NGC-201	NGC ODU Low Temperature Kit (-40 C)
NGC-202	NGC ODU High Temperature Kit (+60 C)
NGC-206	NGC Exterior Emergency Stop Button
NGC-207	Pre Movement Alert Warning Light And Annunciator
NGC-211	Dual Path NGC Redundancy
NGC-AESC	Environmental System Controller

Antenna controller, motorization and options are detailed in specific bulletins, please contact CPI Antenna Systems Division..

9.1 Meter ESA

Feed Matrix

C- BAND FEED SYSTEMS	PORT	Co-Pol	CP	LP	RX 3.625 - 4.2 GHz	RX 3.4 - 4.2 GHz	TX 5.850 - 6.425 GHz	TX 5.850 -6.725 GHz	TX 5.725 - 6.725 GHz
4CPWWC-91-206	4		X			X			X
4LPWWC-91-VP	4			X		X			X

Ku- BAND FEED SYSTEMS	PORT	LP	RX 10.7 - 12.75 GHz	RX 10.7 - 11.7 GHz	TX 12.75- 13.25 GHz	TX 13.75- 14.8 GHz
4LPKU-91-1	4	X	X			X

K- BAND FEED SYSTEMS	PORT	CP	LP	RX 10.7 - 12.75 GHz	TX 17.3- 18.4 GHz
4CPKK-91	4	X		X	X
4LPKK-91-1-VP	4		X	X	X

EARTH STATION ANTENNA

9.1 Meter ESA

Antenna Options and Spares

Anchor Bolt and Template Kits Options	
519083	120° Foundation Kit
726772-0001	180° Foundation Kit
360061	120° Foundation Kit EE/TT&C
268817	180° Foundation Kit EE/TT&C

Azimuth and Elevation Cross Axis Waveguide Options	
XAPC-91	C-Band cross Axis and Polarization Axis Waveguide Kit.
XAPC-91-UPG	C-Band Cross Axis and Polarization Axis Waveguide Kit Upgrade. Upgrades XAPKK-91 for use with 4-port C-Band Feeds.
XAPKU-91	Ku-Band Cross Axis and Polarization Axis Waveguide Kit. Single run for 2-Port Ku-Band Feeds.
XAPKU-91-UPG	Ku-Band Cross Axis and Polarization Axis Waveguide Kit Upgrade. Upgrades XAPKU-91 for use with 4-Port Ku-Band Feeds. Provides Additional Waveguide Run.
XAPKK-91	K-Band Cross Axis and Polarization Axis Waveguide Kit. Single run for 2-Port K-Band Feeds.
XAPKK-91-UPG	K-Band Cross Axis and Polarization Axis Waveguide Kit Upgrade. Upgrades XAPKK-91 for use with 4-Port K-Band Feeds. Provides Additional Waveguide Run.

Heating Options	
FHC-91	C-Band Feed Heater
FHX-91	X-Band Feed Heater
FHKUK-91	Ku-K-Band Feed Heater
WEC91R-208-100	Electric Hot Air De-Ice System, 208 VAC, 3 Phase
WEC91R-380-100	Electric Hot Air De-Ice System, 380 VAC, 3 Phase

Hub Equipment Options	
EMRGYLT-115	Emergency Hub Light Kit, 115 VAC
EMRGYLT-230	Emergency Hub Light Kit, 230 VAC
721734	Fan Vent Kit, 115 VAC
578904	Fan Vent Kit, 230 VAC
HUBHTR-230	Antenna Hub Heater, 230 VAC
HUBLCNTR-115/240	Hub Power Center, 115/240 VAC
HUBLCNTR-230	Hub Power Center, 230 VAC
HUBLT-115	Hub Light Kit, 115 VAC
HUBLT-230	Hub Light Kit, 230 VAC

Safety Options	
ANTGND-91	Foundation Installed Grounding Kit
LTK9	Lightning Rod Kit
MANPL113-120	Maintenance Platform and Ladder Kit 120° Mnt
MANPL113-180	Maintenance Platform and Ladder Kit 180° Mnt
MANPL113-ENH	Full Maintenance Platform and Ladder Kit use with 120° or 180° Mounts
OBWRNLT-UNV	Obstruction Warning Light Kit

Other Options	
209906-91	Lubrication and Maintenance Kit
201769-91	Handwheel Kit
FTST	Feed System Testing
TK-VEP-LG	Tool Kit, Large Motorized Antennas
1011807	TT&C Mount Alignment Kit
516212	Theodolite Alignment Kit
ANGVERN-91	Manual Angle Indicator

Environment Systems Options	
PDKUK-91-208	Precipitation Deviator Ku-K, 208/230 VAC.
PDKUK-91-380	Precipitation Deviator Ku-K, 380/415 VAC.

CPI Antenna Systems Division
 1120 Jupiter Road, Suite 102
 Plano Texas 75074
 USA
 Phone: +1-214-291-7654
 Fax: +1-214-291-7655
www.cpii.com/ascsignal
ASC.Sales@cpii.com